

LIGO End-to-End Simulation Model

Biplab Bhawal

LIGO, Caltech

- **Contributors:** Matt Evans, Malik Rakhmanov, Hiro Yamamoto
- March 10, 2001
- Pac. Coast Grav. Meet
- Univ. of California, Santa Barbara

LIGO Interferometer

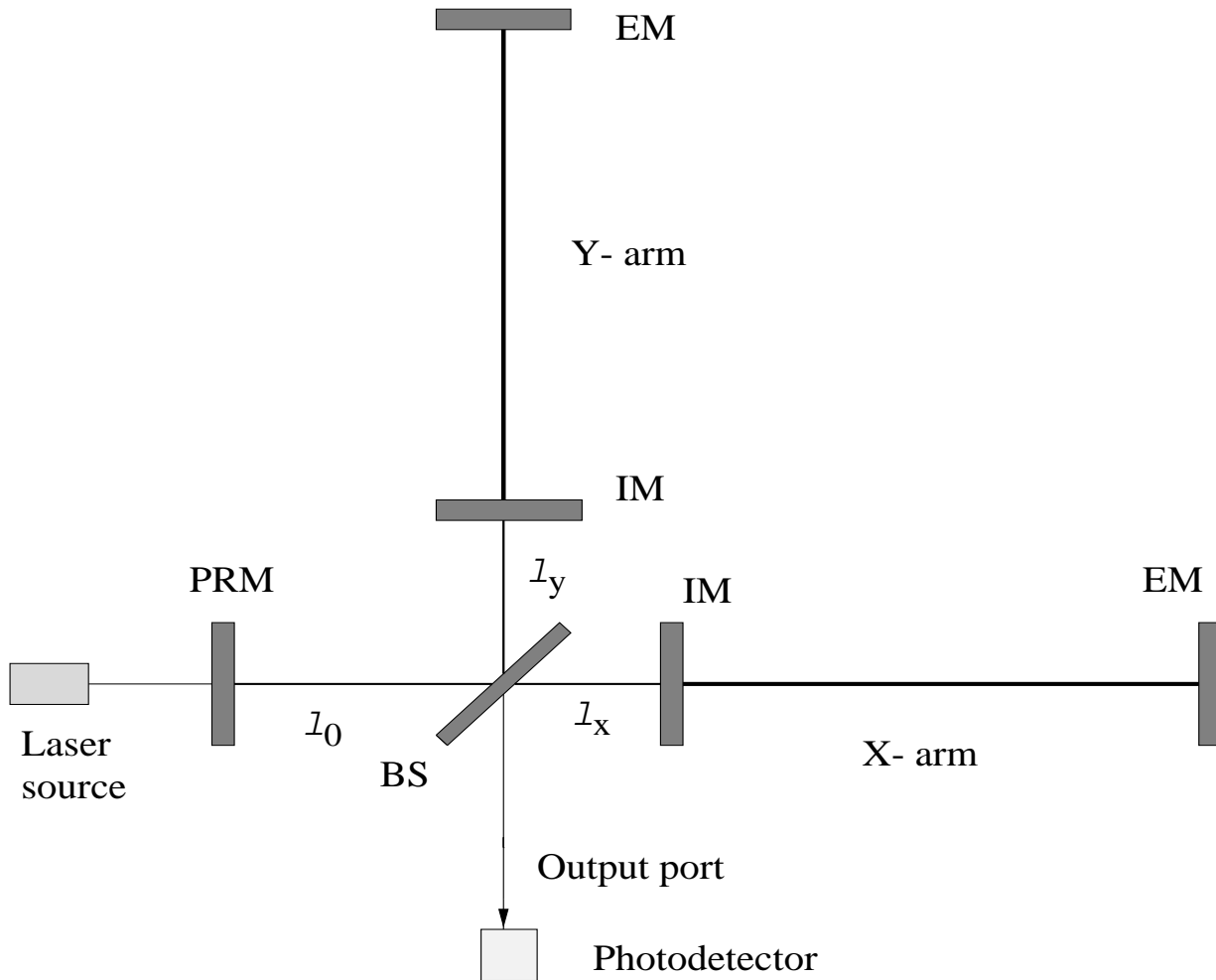

- ›› Interferometry with suspended mirrors
- ›› A coupled, dynamic, multi-length, non-linear system

E2E : Definition & Aims

- **Definition:** A general simulation framework which enables studies of optical, electronic and mechanical components and their interaction in interferometer-based gravitational-wave detectors.

- **Aims :**
 - ›› Better understanding of LIGO-Physics and LIGO-techniques : Dynamics, Misalignments, Noises, Lock-acquisition.
 - ›› Trouble-shooting
 - ›› Helping future design of full LIGO or various subsystems

How To Use E2E

- Build up your laboratory:
 - ›› (Like Matlab) E2E provides toolbox with specialised tools for studying all kinds of interferometric GW detectors
 - ›› Set-up your experiment using an easy-to-learn graphical-user-interface called **Alfi**
 - ›› Basic tools: laser source, mirror, propagator, telescope, lens, modulator, detector, digital filter, power-meter,simple algebraic and logic functions..... etc.
 - ›› Set parameters of modules, make connections among them, ... **run**
 - ›› Example E2E box: Fabry-Perot Cavity (using primitive modules)

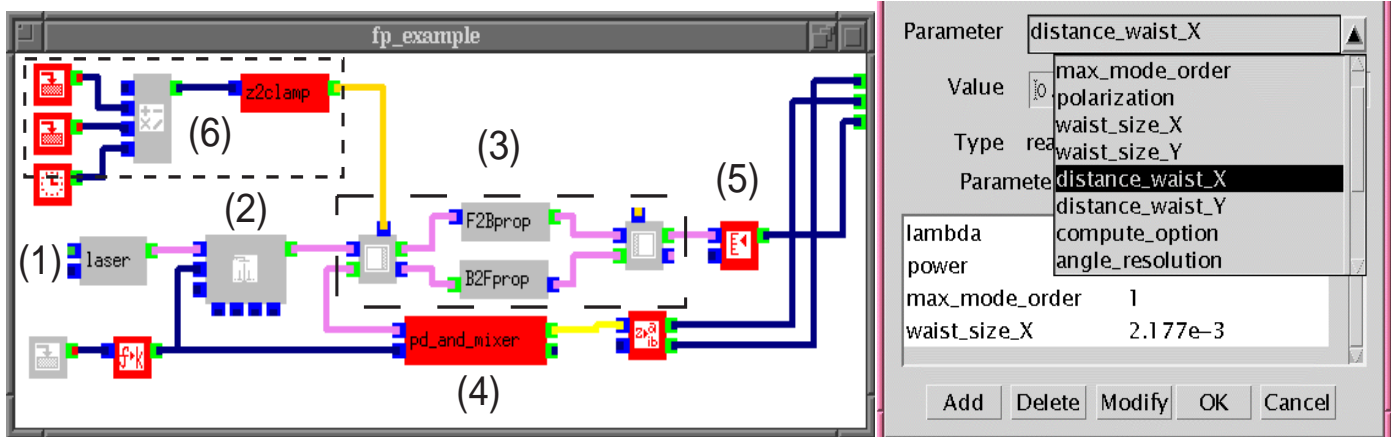

(a) GUI front-end of e2e

(b) parameter setting windows

Time-domain Modal Model

- ›› “field” carries information about frequencies and spatial modes
- ›› spatial modes in Hermite-Gaussian basis
- ›› Tilt, shift, curvature mismatch are treated using mode decomposition matrix
- ›› Modal basis changes (i) after passing thru lens/curved mirror (ii) on reflection at an angle from a curved mirror

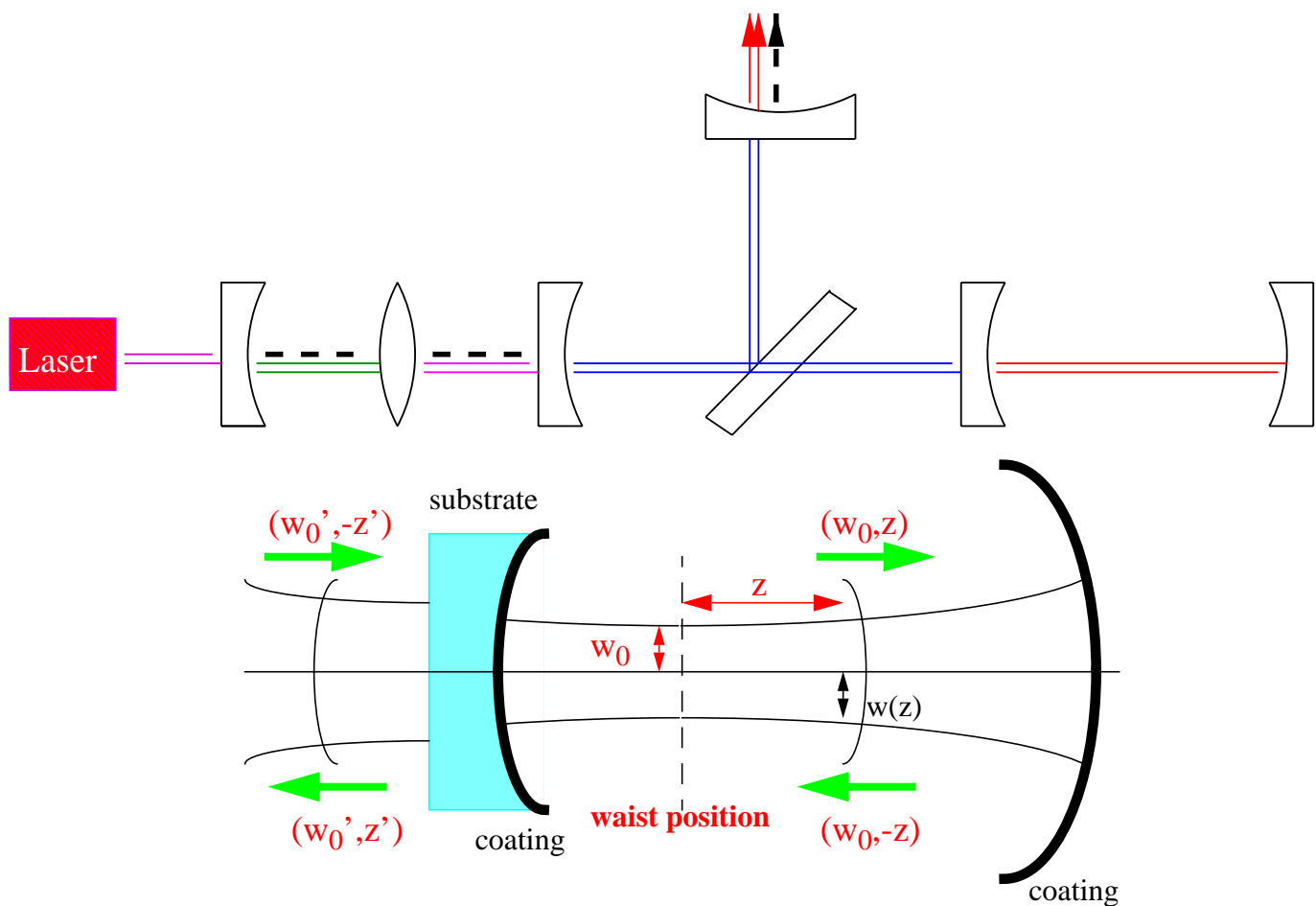

Composite Systems

(*summation modules*)

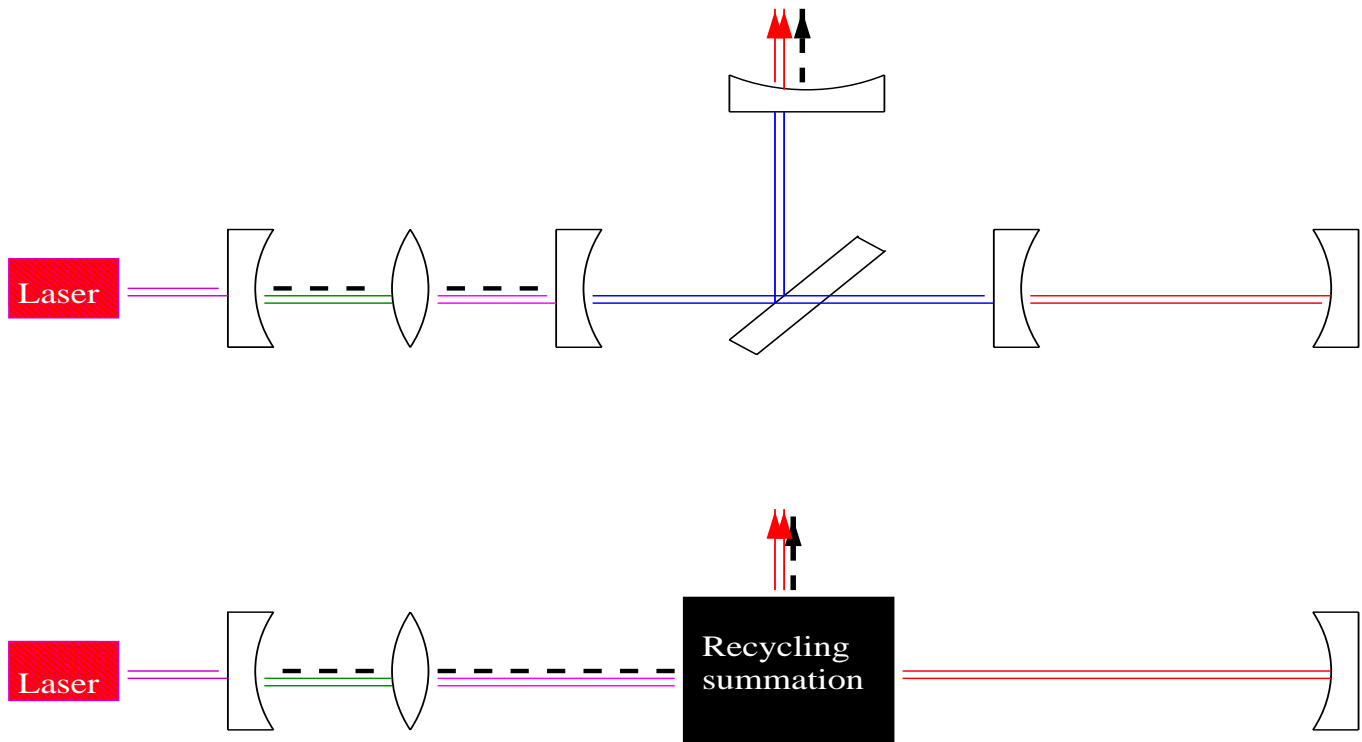

- Aim: fast computation
 - ›› Fabry-Perot cav
 - ›› triangular cavity
 - ›› power-recycled Michelson cavity or the LIGO recycling cavity

Modularity & Flexibility of E2E

- You can study any configuration
- You can look at field at any port and analyze
- You, **as user**, donot need to know C++ or even programming or to touch the original code.
- You, **as developer**, can introduce new physics modules easily without touching the rest of the code but utilizing full advantage of that.

Hanford 2Km Arm: First light (Actual and E2E-simulated)

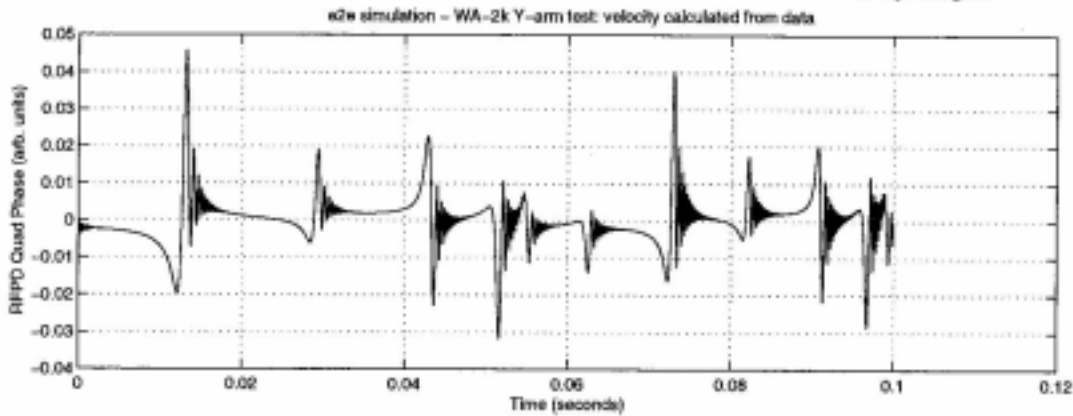
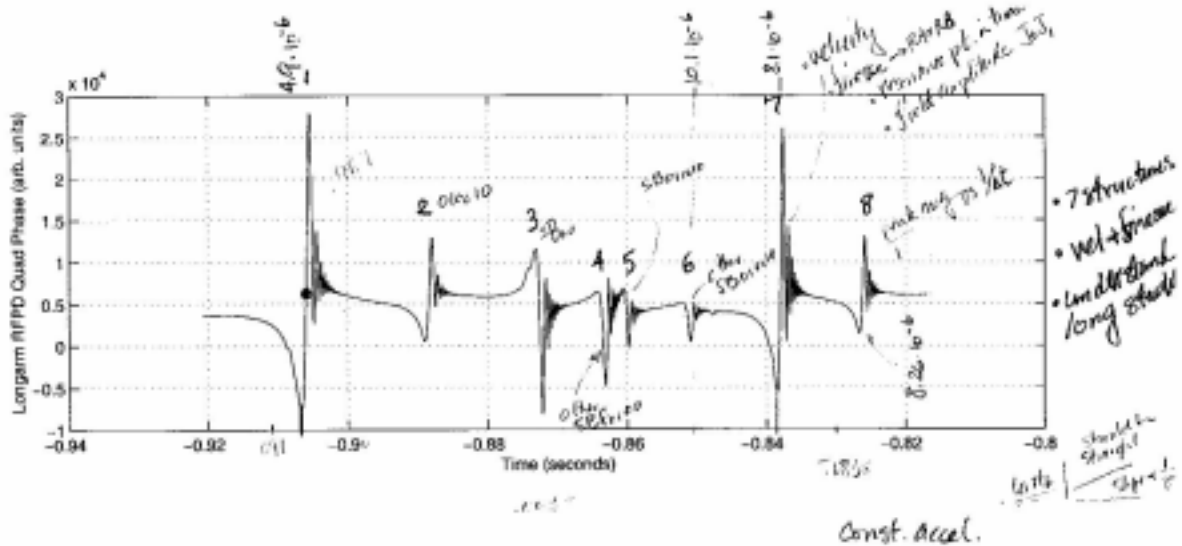

›› December, 1999

LIGO Lock-Acquisition States

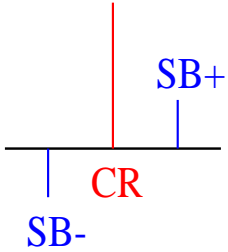
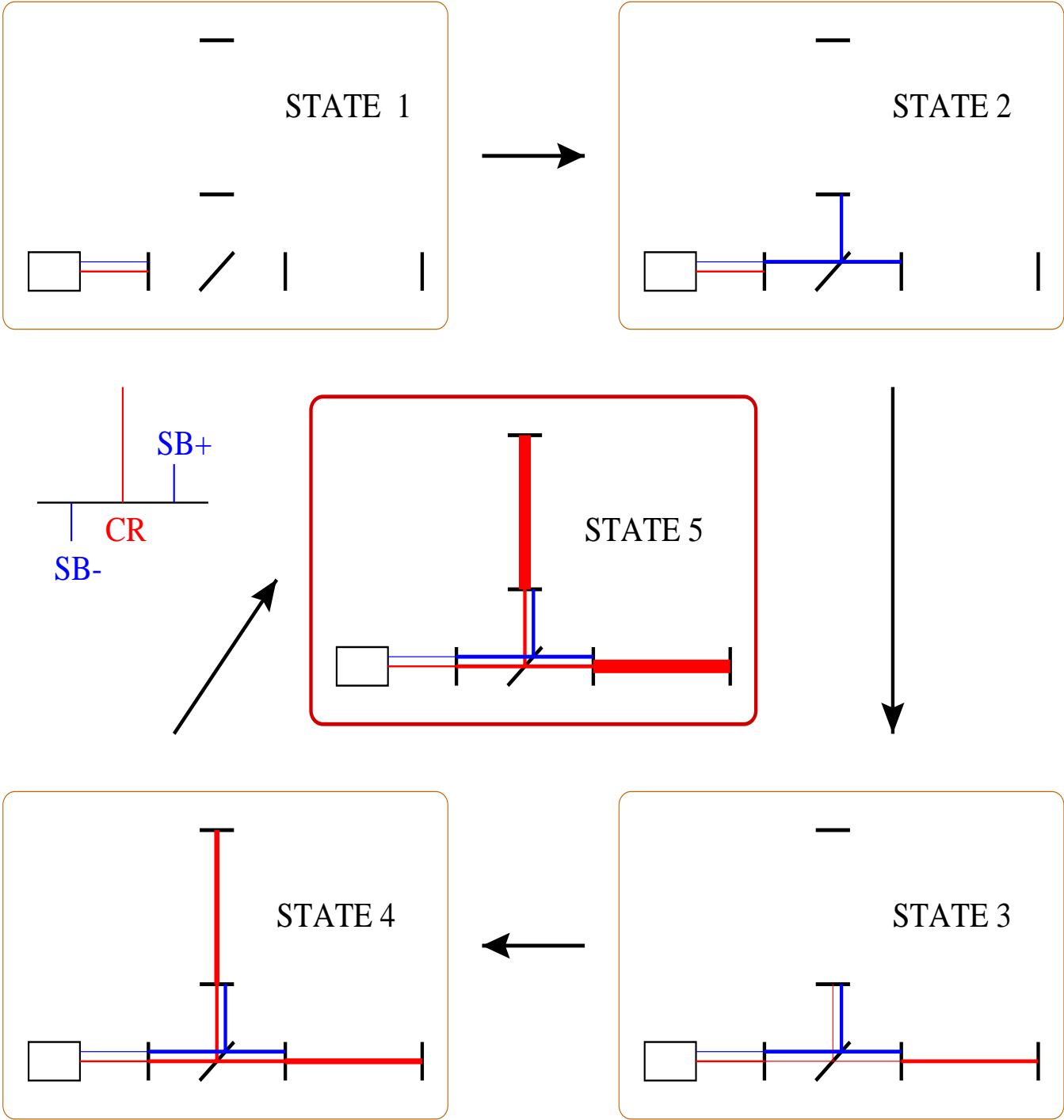

Lock-Acquisition

(actual Hanford 2KM IFO data)

›› December, 2000

Fig1 LHO 2k IFO data

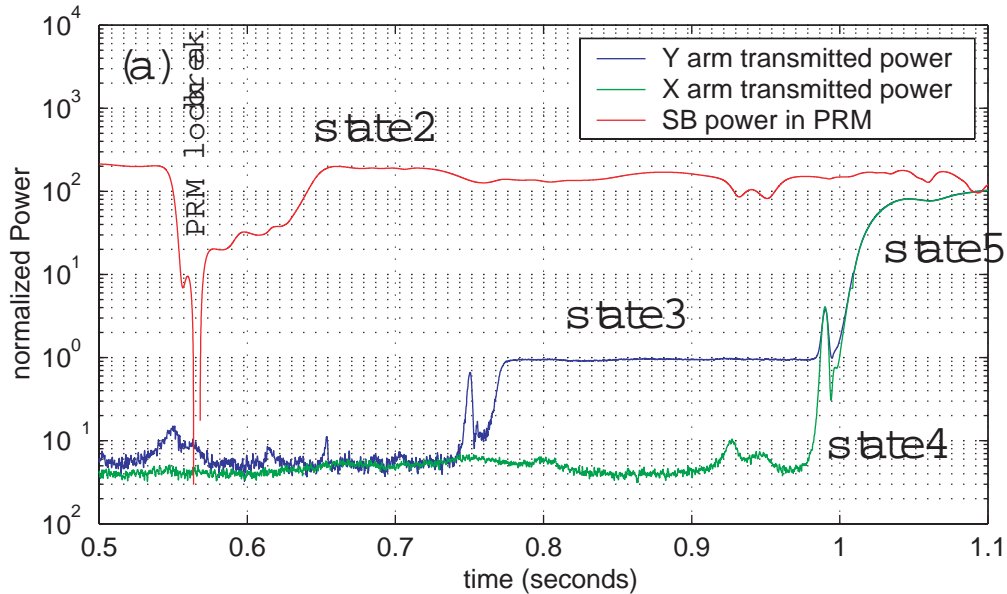

Arm powers are normalized by the power when one arm is locked.
SB power is normalized by the input SB power.

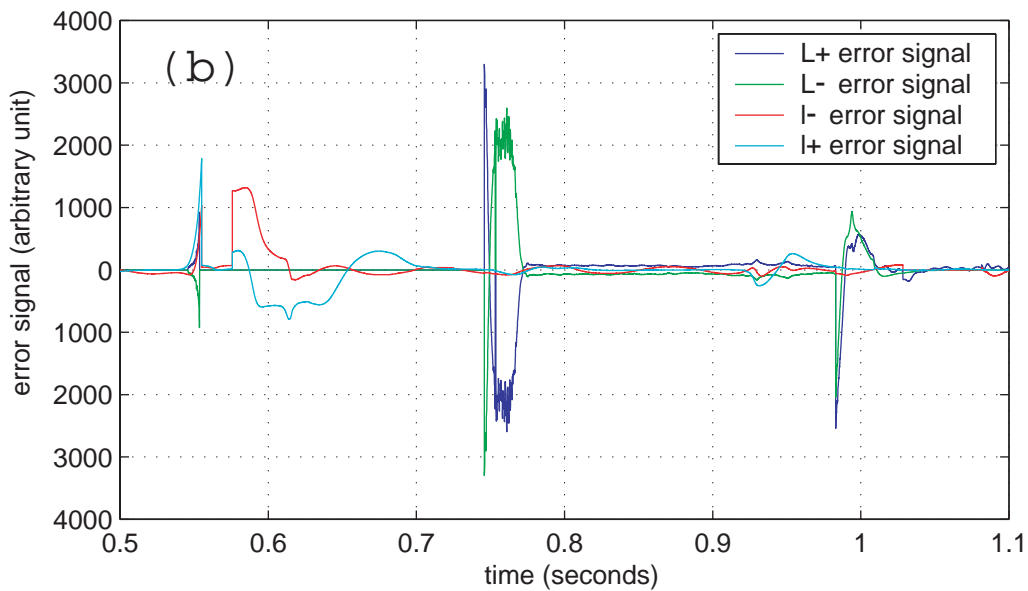

Lock-Acquisition (E2E-simulated data)

Figure 2. Simulated signal

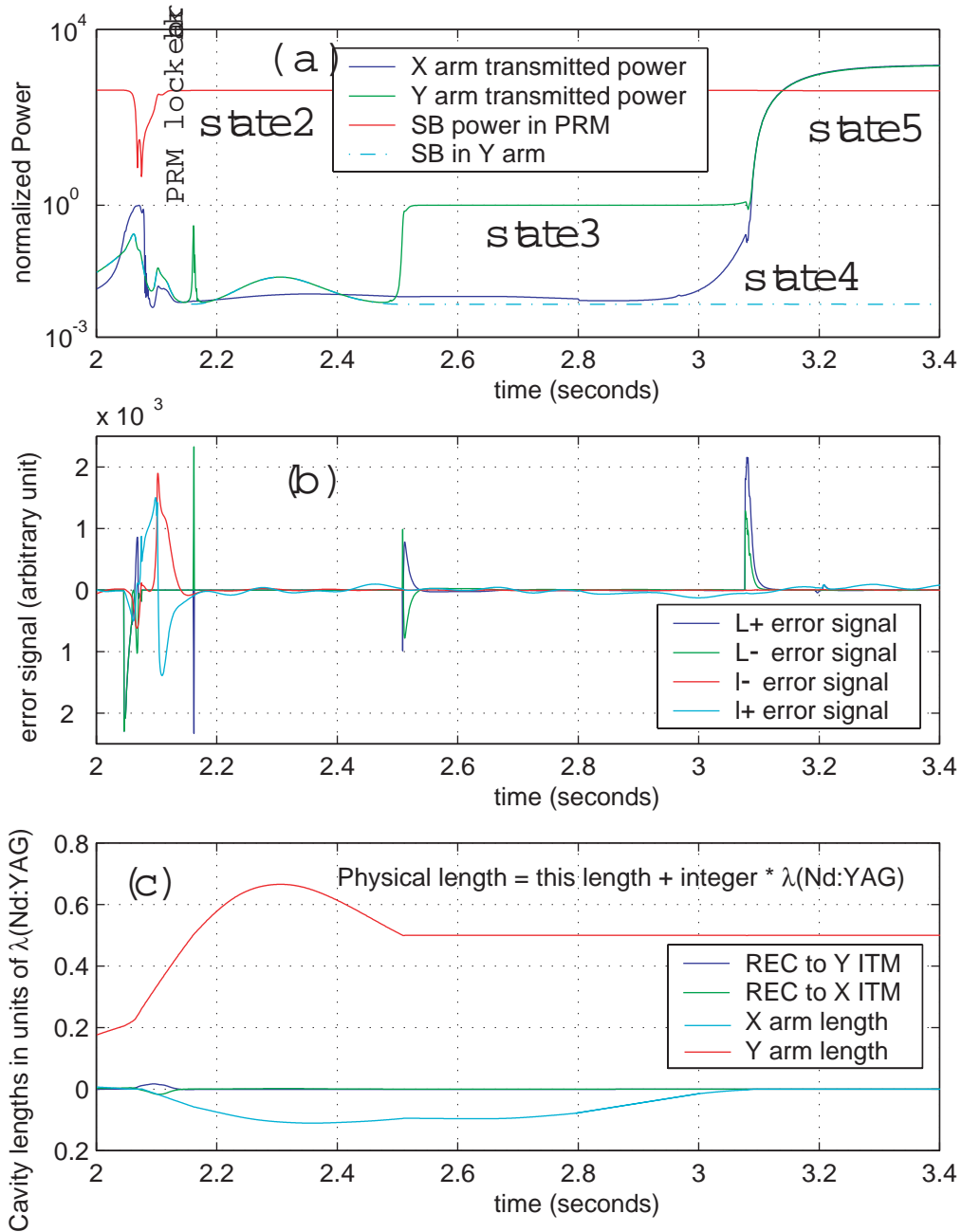

Lock-acquisition & misalignments

(Study: power fluctuations, lock duration.....)

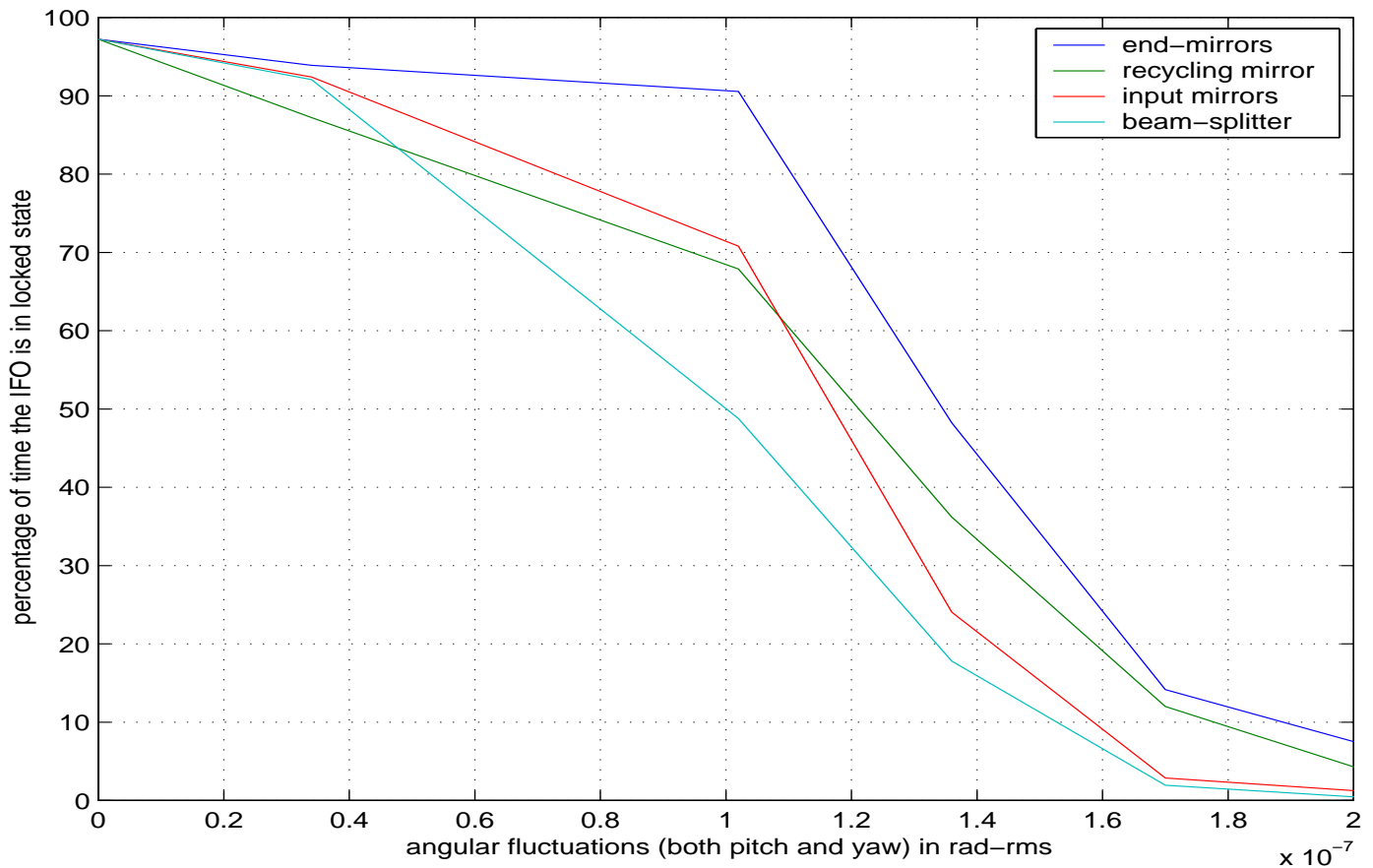
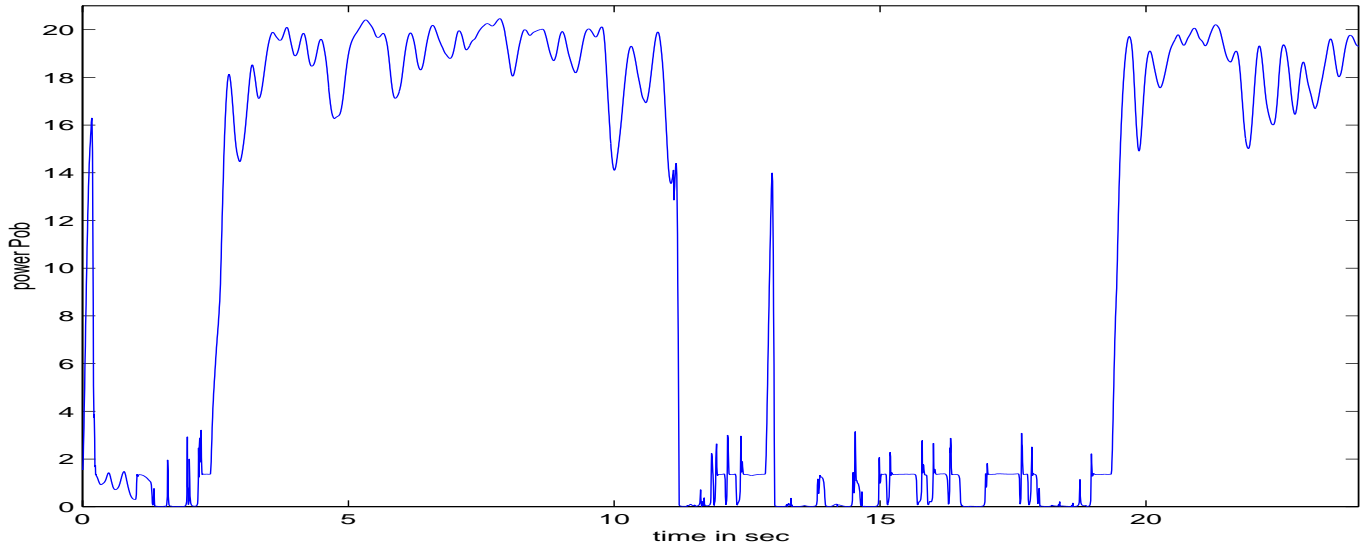

E2E for GW Data-analysis

- The modeled IFO is under your control
- Put noises and complexities to whatever level you feel comfortable about.
- Simulate Grav. waves
- Look at changes in IFO signals
- Generate data-stream and use your tools to analyse and extract signals

- OR
 - ›› Try to understand the actual data-stream and noises in it comparing with simulation that includes causes you guess.