

Some aspects of magnetotransport in graphite

Shan-Wen Tsai

(UC - Riverside)

Art Hebard and Dmitrii Maslov (Univ. of Florida)

Xu Du (Rutgers)

KITP, January 2007

HOPG Graphite, sample geometry:

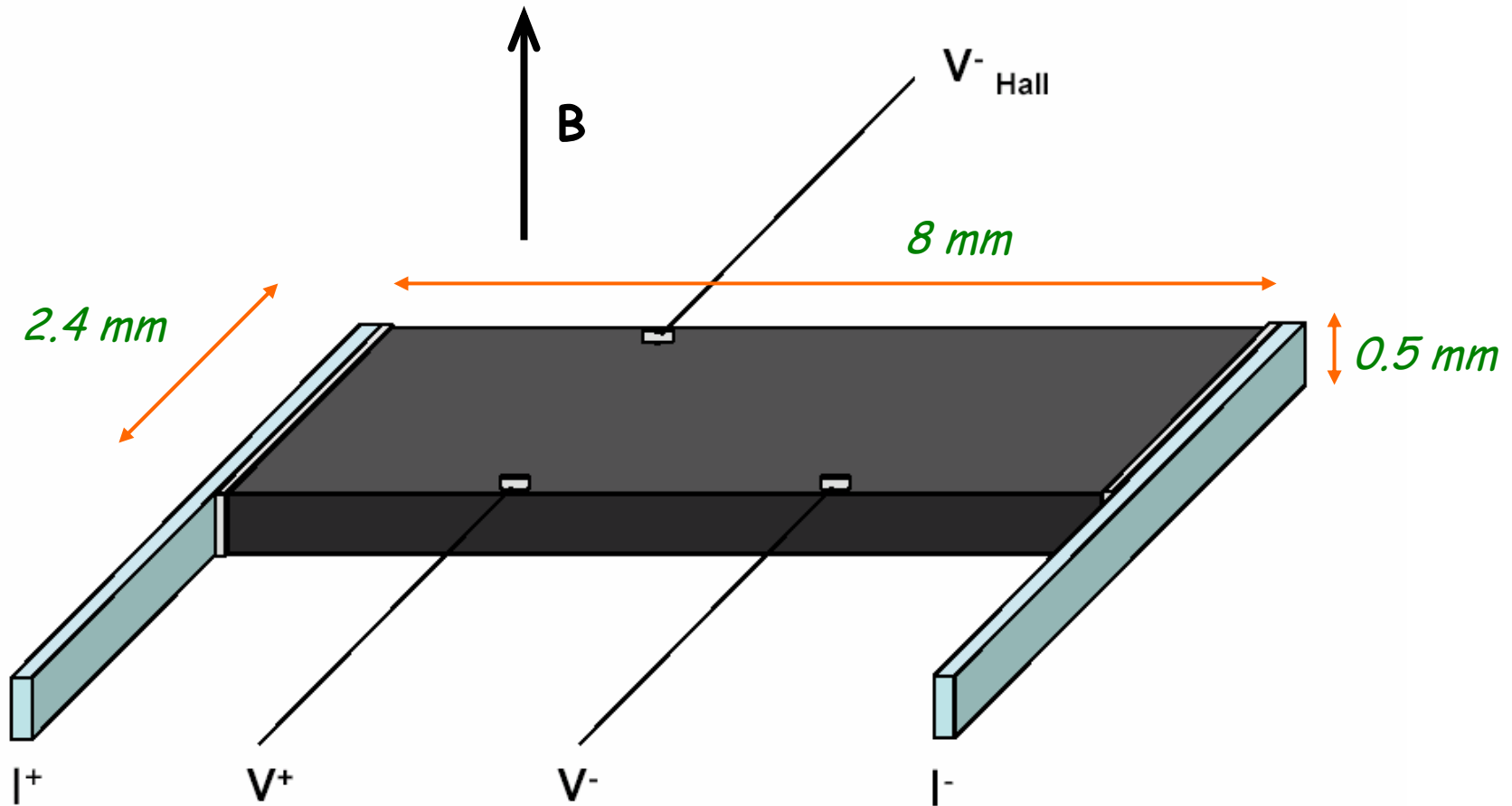

Xu Du (Rutgers), A. F. Hebard (UF)

Magnetoresistance at low fields

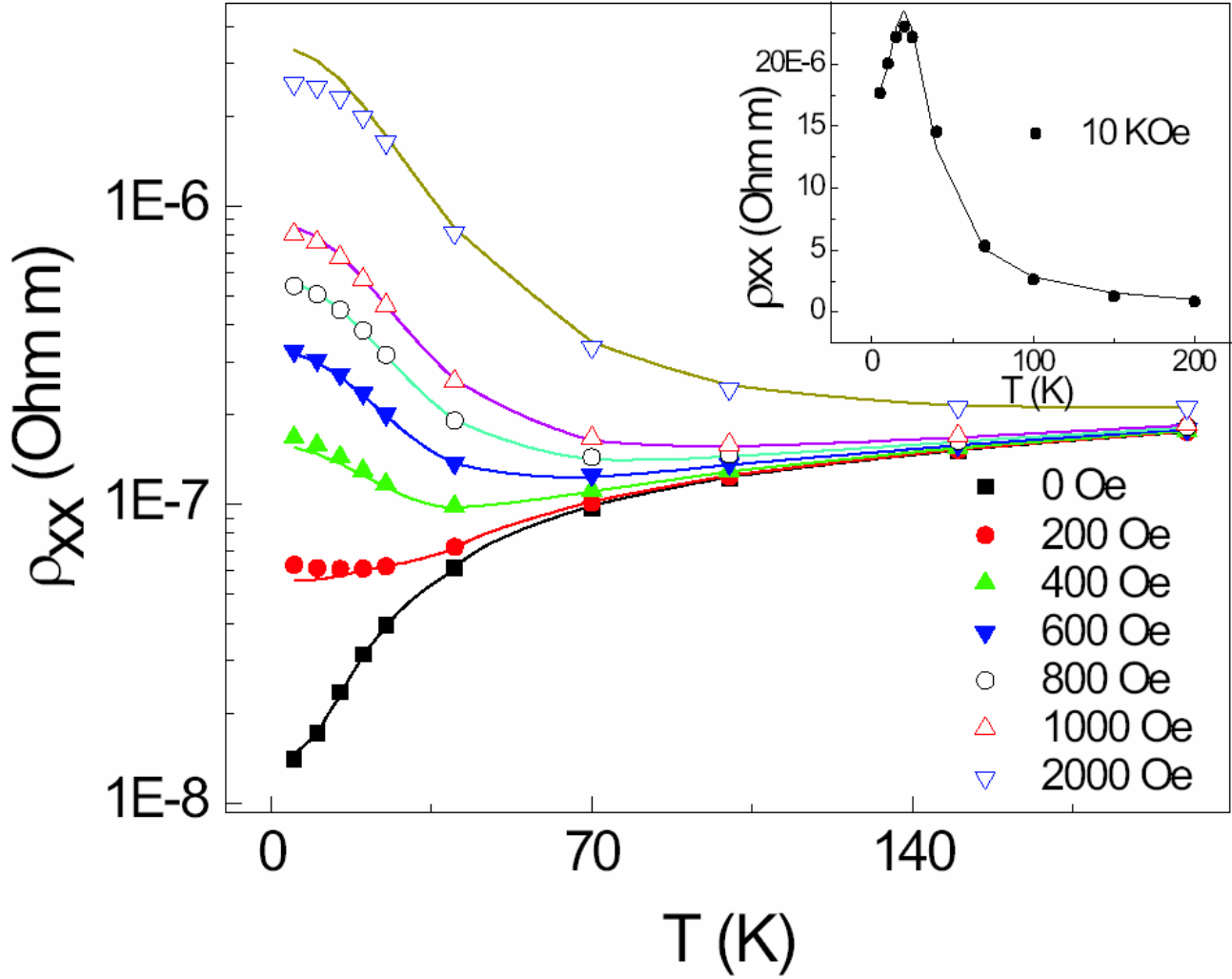

Two-band model:

$$\rho_{xx} = \frac{\rho_1 \rho_2 (\rho_1 + \rho_2) + (\rho_1 R_2^2 + \rho_2 R_1^2) B^2}{(\rho_1 + \rho_2)^2 + (R_1 + R_2)^2 B^2}$$

$$\rho_i = m_i / n_i e^2 \tau_i$$

$$R_i = 1 / q_i n_i$$

If $\rho_{1,2} \sim T^a$ and $R_1 = -R_2 = R$

$$\rho_{xx} = C_0 T^a + C_1 R^2 B^2 / T^a$$

Extracting $n_i(T)$ and $\tau_i(T)$
from measurement of
 $\rho_{xx}(T,B)$ and $\rho_{xy}(T,B)$:

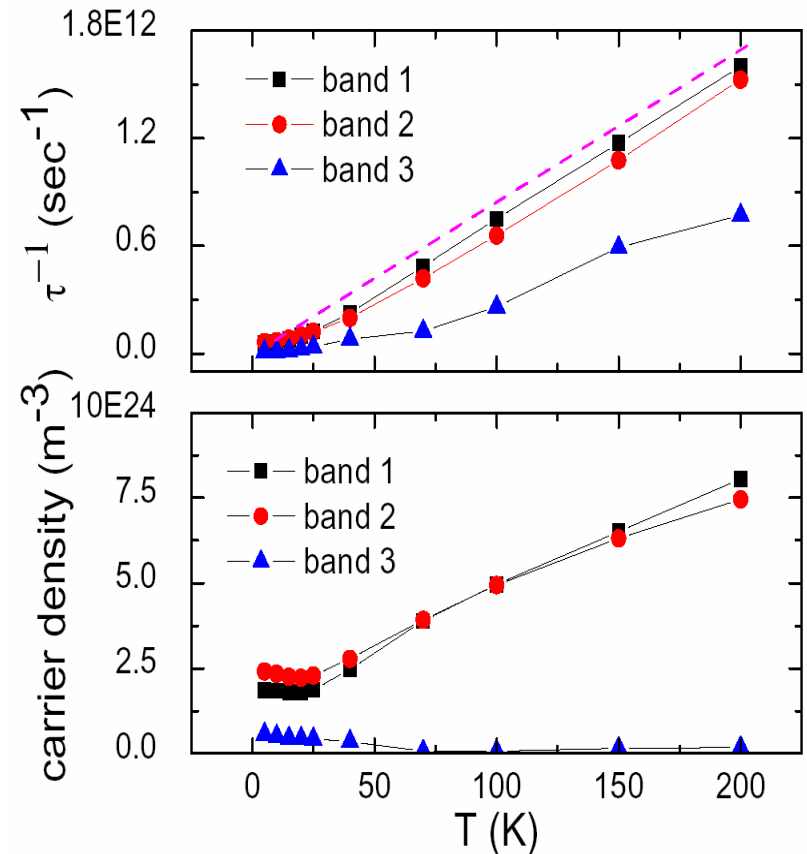

“Metal-insulator-like” behavior in semimetals due to existence of the interval:

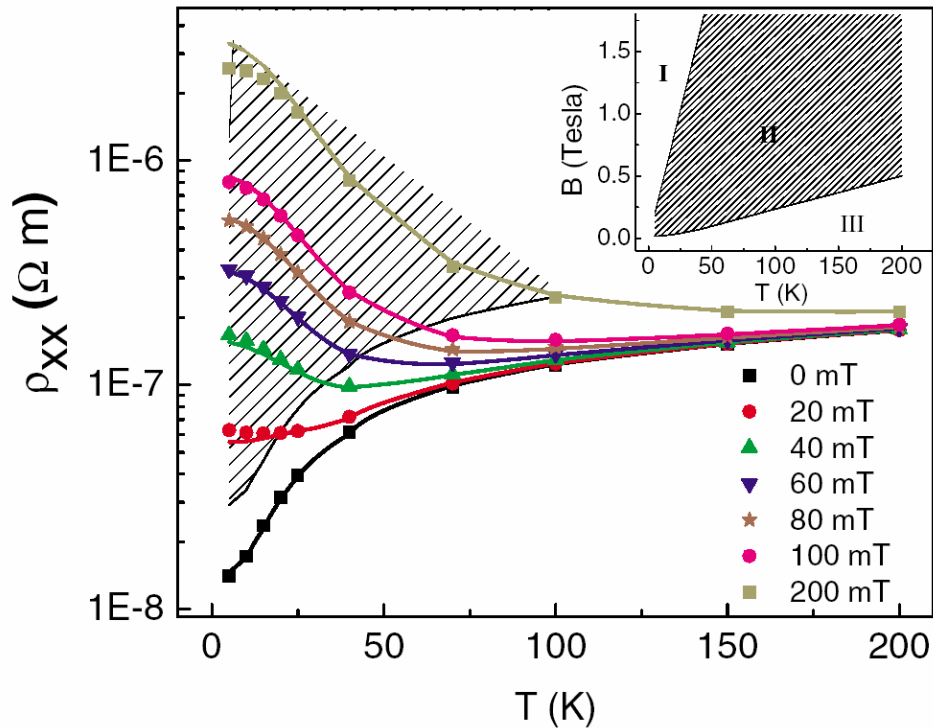

$$\hbar/\tau < \hbar\omega_c \ll k_B T$$

- clean
- small cyclotron mass
- low carrier density

electron-phonon: $\tau^{-1} \simeq (k_F a_0) (m^*/m_0) k_B T / \hbar$

X. Du, SWT, D. L. Maslov, A. F. Hebard, PRL (2005)

Similar behavior in bismuth:

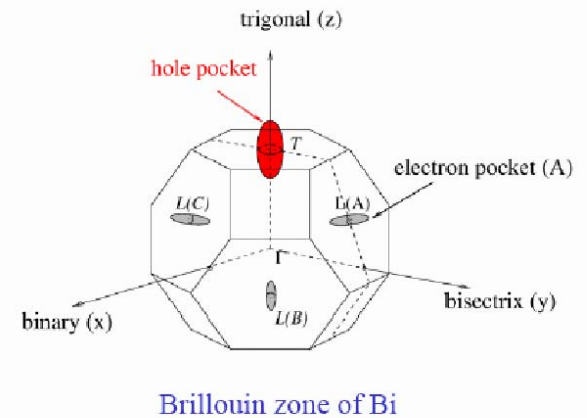
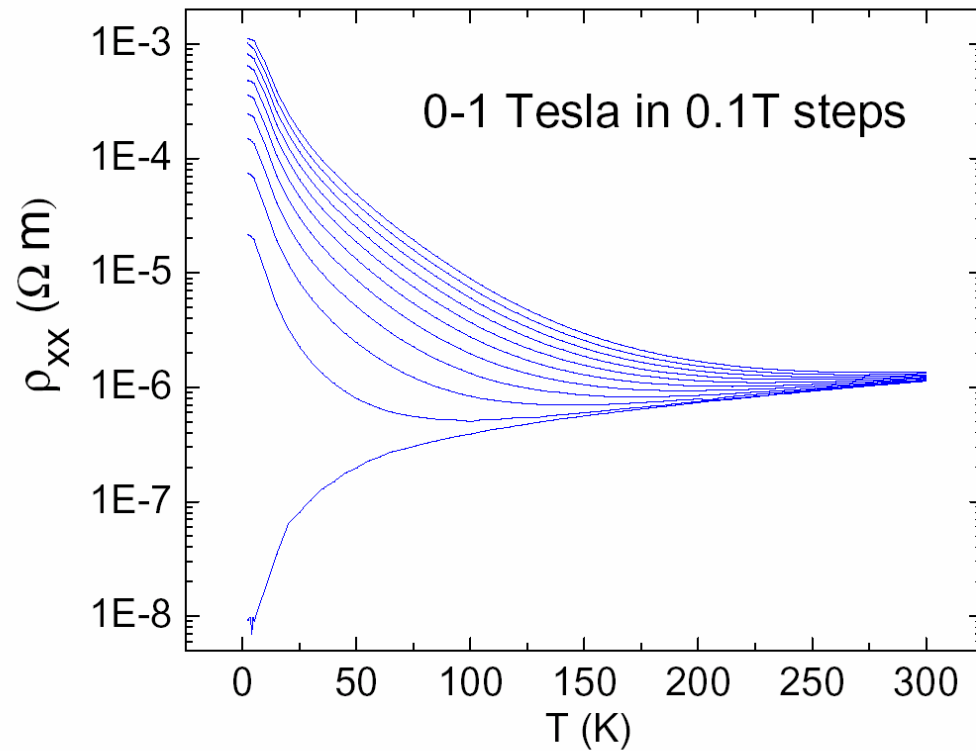

X. Du, SWT, D. L. Maslov, A. F. Hebard, PRL (2005)

Graphite in the Ultra Quantum Limit

R_c

cax: Current and Field in c-axis direction

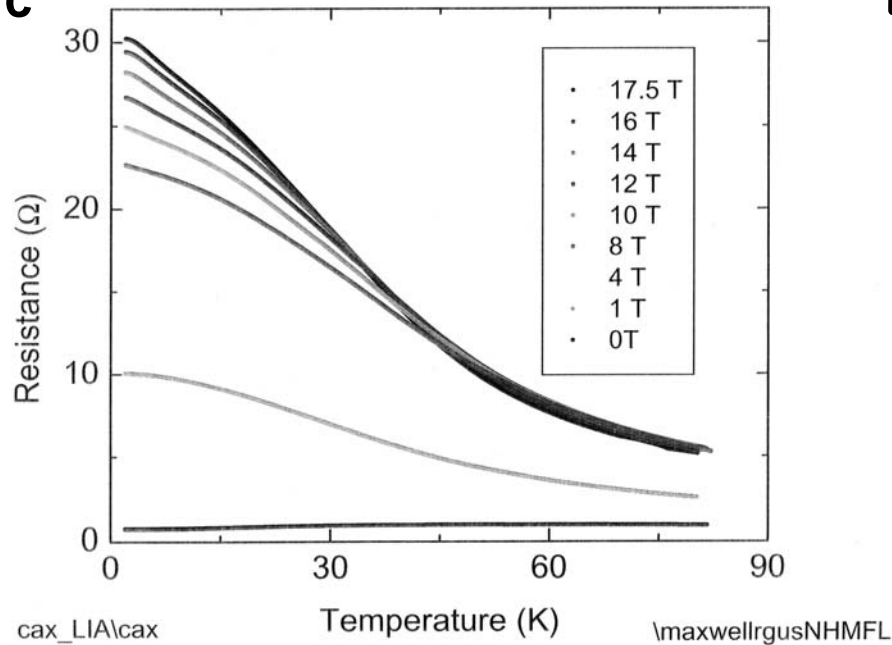

R_{ab}

cab: Current in ab plane, field in c-axis direction

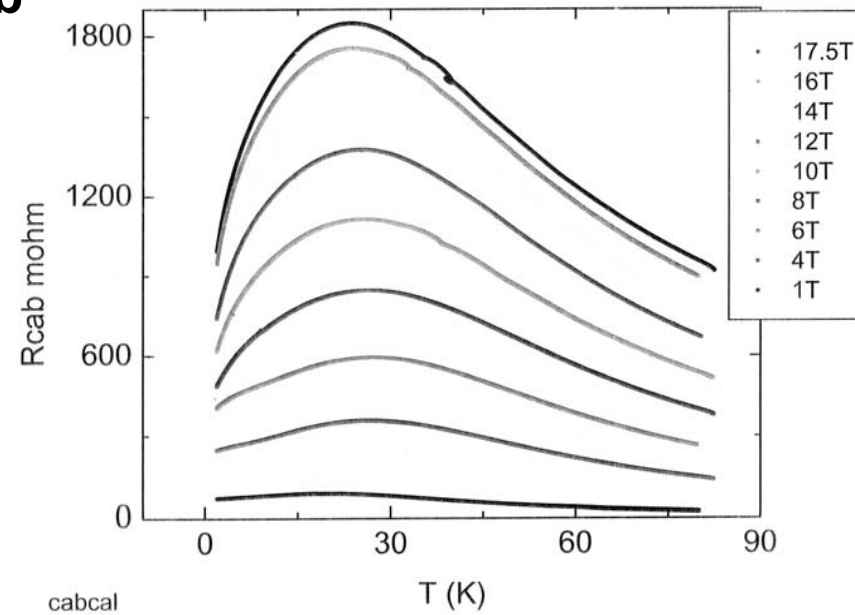

Xu Du (Rutgers), A. F. Hebard (UF)

$$\sigma_c = \frac{ne^2\tau}{m_{||}} \sim \tau \sim T^{\beta(B)}$$

$$\sigma_{ab} = \nu_{Fe}^2 D_{\perp} \sim \frac{1}{\tau} \sim T^{-\beta(B)}$$

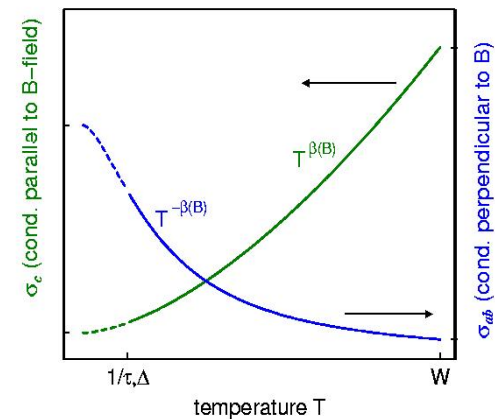

SWT, D. L. Maslov, L. I. Glazman, PRB (2002)

The Ultra-Quantum Limit (UQL):

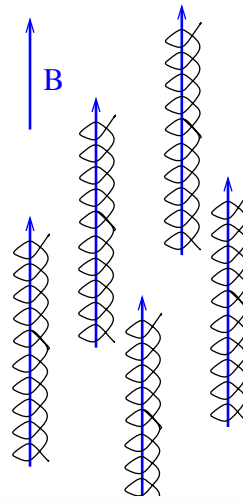
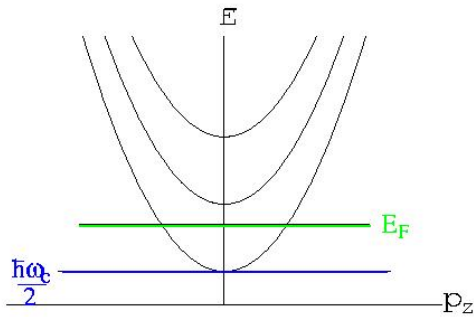

(Brazovsky 71)
 (Yoshioka + Fukuyama 81)
 (Yakovenko 93)

$$\frac{\partial \gamma(\mathbf{r}_\perp, \xi)}{\partial \xi} = \int d^2 r'_\perp \gamma(\mathbf{r}'_\perp, \xi) \gamma(\mathbf{r}_\perp - \mathbf{r}'_\perp, \xi) [1 - e^{i(\mathbf{r}_\perp \wedge \mathbf{r}'_\perp)}]$$

$$\frac{\partial \Gamma(\mathbf{k}_\perp, \xi)}{\partial \xi} = \Gamma^2(\mathbf{k}_\perp, \xi) - \int \frac{d^2 q_1 d^2 q_2}{(2\pi)^2} \Gamma(\mathbf{q}_1, \xi) \Gamma(\mathbf{q}_2, \xi) e^{i(\mathbf{q}_2 \wedge \mathbf{k}_\perp + \mathbf{k}_\perp \wedge \mathbf{q}_1 + \mathbf{q}_1 \wedge \mathbf{q}_2)}$$

Strict 1D (Luttinger-liquid):

$$\frac{\partial \Gamma(\xi)}{\partial \xi} = 0$$

3D + B, infinite-range interaction:

$$\frac{\partial \Gamma(0, \xi)}{\partial \xi} = 0$$

Initial condition for the RG flow:

$$\gamma_0(\mathbf{r}_\perp) = \frac{1}{(2\pi)^3 v_F} \left[e^{-r_\perp^2/2} U(0, \mathbf{r}_\perp) - (2\pi \ell_B^2) \int \frac{d^2 q_\perp}{(2\pi)^2} e^{i\mathbf{r}_\perp \cdot \mathbf{r}_\perp - q_\perp^2 \ell_B^2/2} U_0(2k_F, \mathbf{r}_\perp) \right]$$

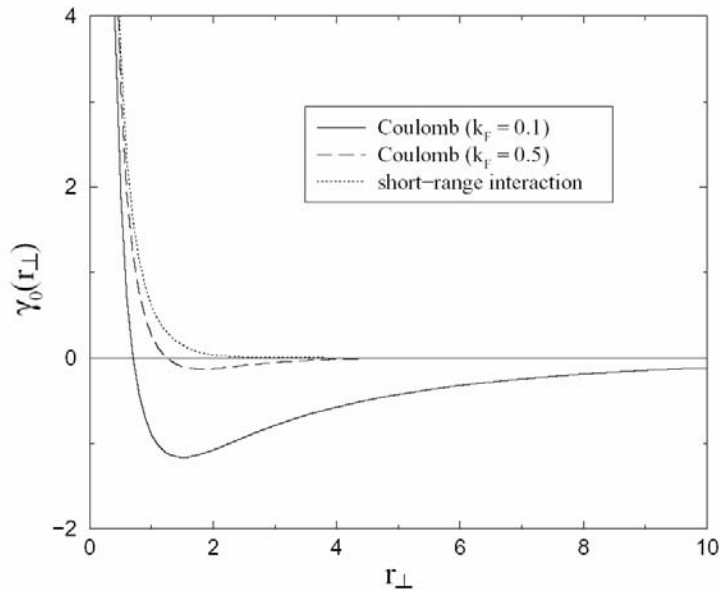

Instability (for $\kappa = 0.1$):

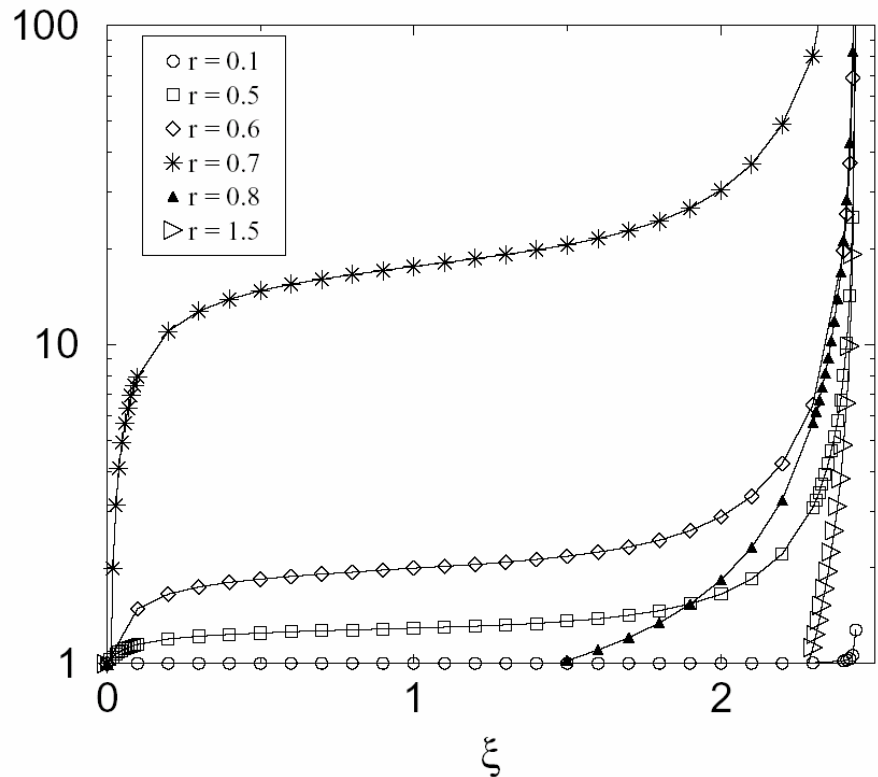

Instability at high magnetic fields:

Short-range interaction: "1D" Charge-density-wave
($2k_F$ charge modulation along the magnetic field direction)

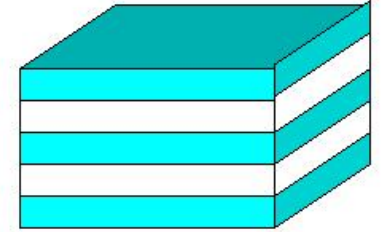

Long-range interaction: "3D" Charge-density wave
($2k_F$ charge modulation along the magnetic field direction and κ modulation in the transverse direction)

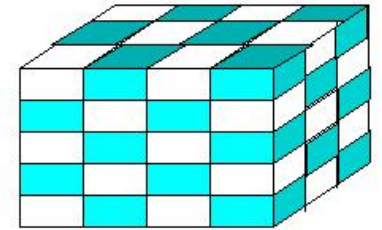

expts:

Y.Iye et al. 1982

Y.Iye and G.Dresselhaus 1985

H.Ochimizu et al. 1992

H.Yaguchi and J.Singleton 1998

Tunneling density of states (B + e-e interaction)

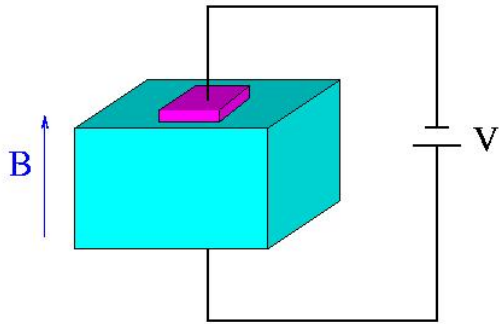

$$dt/d\ln\varepsilon = (\Gamma_0/2) t (1 - |t|^2)$$

$$t \sim |E - E_F|^{\Gamma_0/2}$$

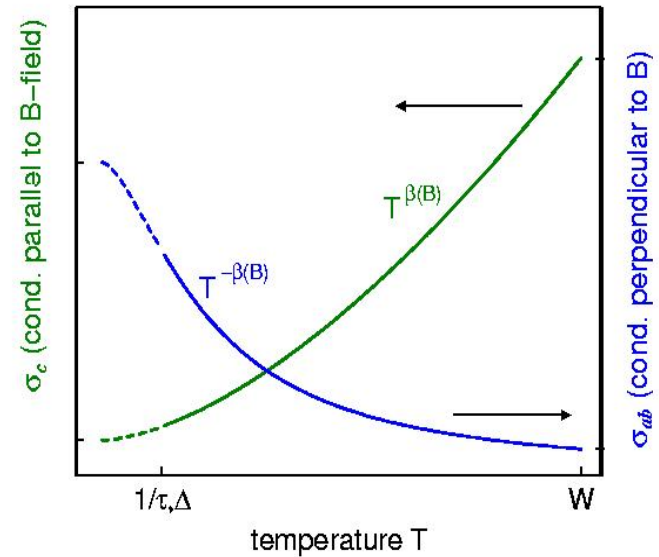
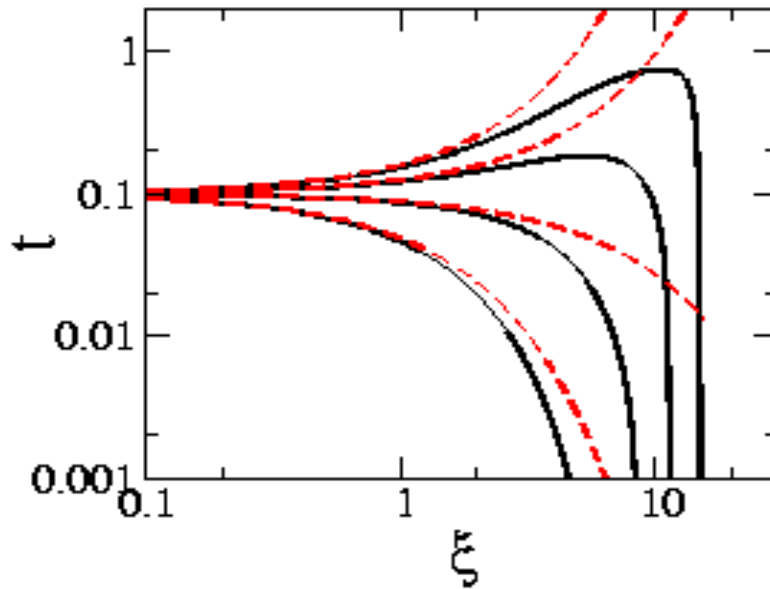

$$\Delta = W \exp(-av_F/e^2)$$

$$E_{PL} \simeq E \exp(-\pi v_F/e^2 |\ln \kappa|)$$